

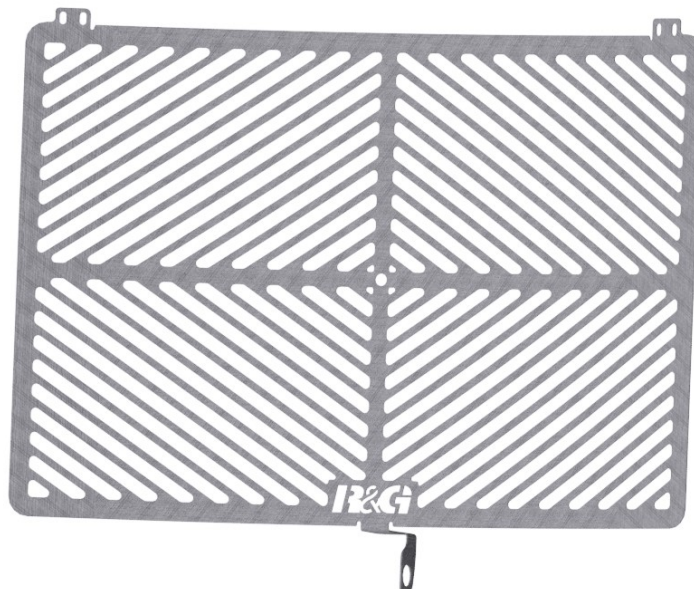

**FITTING INSTRUCTIONS FOR SRG0080 STAINLESS RADIATOR GUARD
YAMAHA YZF-R1M 2020-**



Picture A

THIS KIT CONTAINS THE ITEMS PICTURED AND LABELLED OVER PAGE.

SOME PARTS MAY BE SHOWN FOR CLARITY OF INSTRUCTIONS ONLY.

DO NOT PROCEED UNTIL YOU ARE SURE ALL PARTS ARE PRESENT.

PLEASE READ ALL INSTRUCTIONS BEFORE PROCEEDING.

**IF IN ANY DOUBT WHEN FITTING OUR PRODUCTS, CONSULT ONE OF OUR DEALERS
OR HAVE FITTED BY A QUALIFIED TECHNICIAN.**

PLEASE NOTE THAT THE WAY THE KIT IS PACKED DOES NOT NECESSARILY REPRESENT THE WAY OF
MOUNTING TO THE BIKE.

IN THE EVENT OF RUBBER WASHERS BEING USED TO HOLD COMPONENTS ONTO BOLTS,
THESE RUBBER WASHERS CAN BE THROWN AWAY.

DIGITAL COPIES OF THESE INSTRUCTIONS ARE AVAILABLE FROM:

WWW.RG-RACING.COM

R&G Racing

Unit 1, Shelleys Lane, East Worldham, Alton, Hampshire GU34 3AQ.

Tel: +44 (0)1420 89007 Fax +44 (0)1420 87301 www.rg-racing.com Email: info@rg-racing.com



<u>TOOLS REQUIRED</u>	<u>GENERAL TORQUE SETTINGS</u>
<ul style="list-style-type: none"> • Set of metric Allen keys to include 4 and 5mm • Socket set to include 10mm 	<p>M4 BOLT = 8Nm M5 BOLT = 12Nm M6 BOLT = 15Nm M8 BOLT = 20Nm M10 BOLT = 40Nm M12 BOLT = 40Nm</p>

LEGEND

ITEM No.	DESCRIPTION	QTY
ITEM 1	STAINLESS RADIATOR GUARD (SRG0080)	1
ITEM 2	CABLE TIES (CT0220)	4
ITEM 3	SELF ADHESIVE FOAM	2

R&G Racing

Unit 1, Shelleys Lane, East Worldham, Alton, Hampshire GU34 3AQ.

Tel: +44 (0)1420 89007 Fax +44 (0)1420 87301 www.rg-racing.com Email: info@rg-racing.com



Picture 1



Picture 2

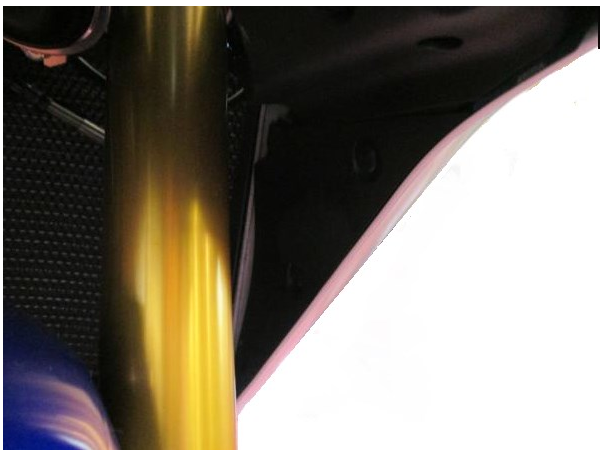

Picture 3

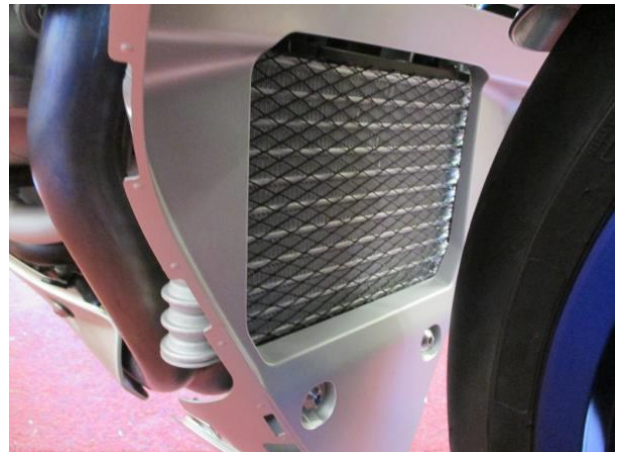

Picture 4



Picture 5

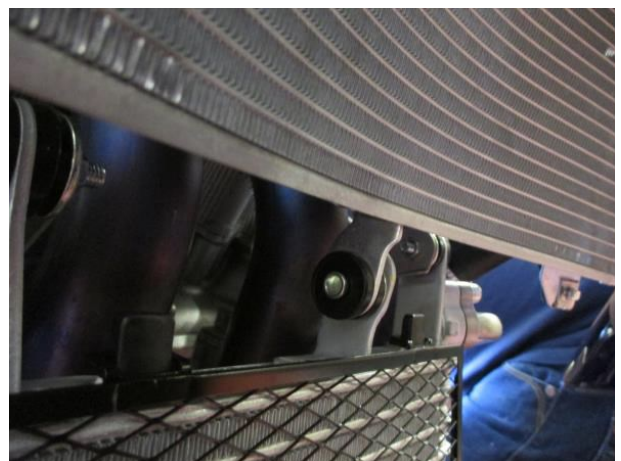

Picture 6

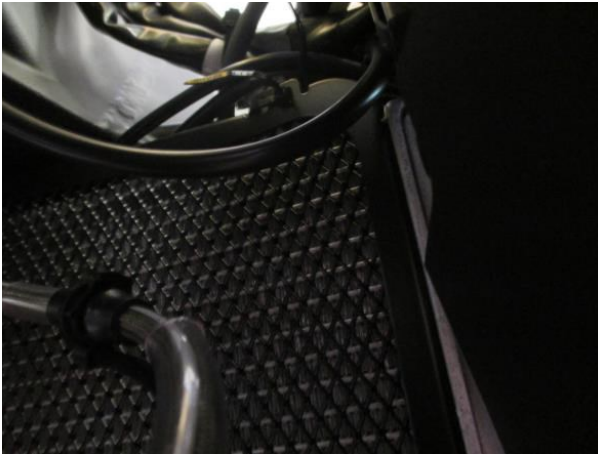

Picture 7



Picture 8



Picture 9

R&G Racing

Unit 1, Shelleys Lane, East Worldham, Alton, Hampshire GU34 3AQ.

Tel: +44 (0)1420 89007 Fax +44 (0)1420 87301 www.rg-racing.com Email: info@rg-racing.com



FITTING INSTRUCTIONS

- To fit the radiator guard to the bike cut the foam strip provided into 10mm wide pieces and stick them to the back of the radiator guard frame, so that they sit between the radiator guard and the radiator.
- Remove the fairings from the bike. To do this on the left side of the bike, remove the three quick release fixtures on the fairing, as arrowed in **picture 1**. On the inside of the fairing, there are four push rivets to be removed, as shown in **pictures 2 & 3**, before the panel can gently pulled forward and be removed from the bike.
- Repeat this process to remove the fairing from the right side of the bike. *Please note there are only three push rivets on the right.*
- Remove the two bolts that secure the oil cooler cowling in place, as shown in **picture 4**.
- Remove the cowling by lifting upwards to clear the two location tabs on the oil cooler, as shown in **picture 5**.
- Remove the lower mounting bolt from the radiator, as shown in **pictures 5 & 6**.
- Offer the R&G radiator into place and re-fit the lower mounting bolt through the radiator guard and then into the radiator mount, before loosely tightening.
- Take one cable tie and fit it through one of the top slotted holes, before looping it around the upper radiator mount and loosely tighten, as shown in **pictures 7 & 8**. Repeat this step on the other side.
- Ensure the radiator guard is correctly mounted, then tighten the lower mounting bolt (ensuring the radiator guard mount sits over the boss and against the rubber) and pull the cable ties tight at the top, before cutting off any excess.
- Re-fit the oil cooler cowling and tighten the two bolts.
- Re-fit the fairings to both sides of the bike and replace bolts in the reverse order of removal.

ISSUE 1 01/11/2019 (BG)

R&G Racing

Unit 1, Shelleys Lane, East Worldham, Alton, Hampshire GU34 3AQ.

Tel: +44 (0)1420 89007 Fax +44 (0)1420 87301 www.rg-racing.com Email: info@rg-racing.com



CONSUMER NOTICE

The catalogue description and any exhibition of samples are only broad indications of the Products and R&G may make design changes which do not diminish their performance or visual appeal and supplying them in such state shall conform to the order. The Buyer acknowledges no representation or warranty (other than as to title) has been given or will apply to the Products other than those in R&G's order or confirmation and the Buyer confirms it has chosen the Products as being of merchantable quality and suitable for its particular purposes. Where R&G fits the Products or undertakes other services it shall exercise reasonable skill and care and rectify any fault free of charge unless the workmanship has been disturbed. The Buyer is responsible for ensuring that the warranty on the motorcycle is not affected by the fitting of the Products. On return of any defective Products R&G shall at its option either supply a replacement or refund the purchase money but shall not be liable if the Products have been modified or used or maintained otherwise than in accordance with R&G's or manufacturer's instructions and good engineering practice or if the defect arises from accident or neglect. Other than identified above and subject to R&G not limiting its liability for causing death and personal injury, it shall not be liable for indirect or consequential loss and otherwise its liability shall be limited to the amounts paid by the Buyer for the Products or the fitting or service concerned. These terms do not affect the Buyer's statutory rights.

R&G RETURNS POLICY (NON-FAULTY GOODS)

Returns must be pre-authorized (if not pre-authorized the return will be rejected). Goods may only be returned direct to us if they were purchased direct from us (customer must prove if necessary). Otherwise to be returned to original vendor. Goods must be in re-sellable condition, in the opinion of R&G. All returns are subject to a 25% restocking and handling fee (25% of the gross value exc. P&P – at the prevailing price at time of purchase). The customer must pay any and all carriage charges. No returns of discontinued products, unless within 14 days of purchase. This policy does not affect your statutory rights and does not refer to faulty goods.

R&G Racing

Unit 1, Shelleys Lane, East Worldham, Alton, Hampshire GU34 3AQ.

Tel: +44 (0)1420 89007 Fax +44 (0)1420 87301 www.rg-racing.com Email: info@rg-racing.com



NOTICE DE MONTAGE SRG0080 PROTECTION RADIATEUR
YAMAHA YZF-R1M 2020-

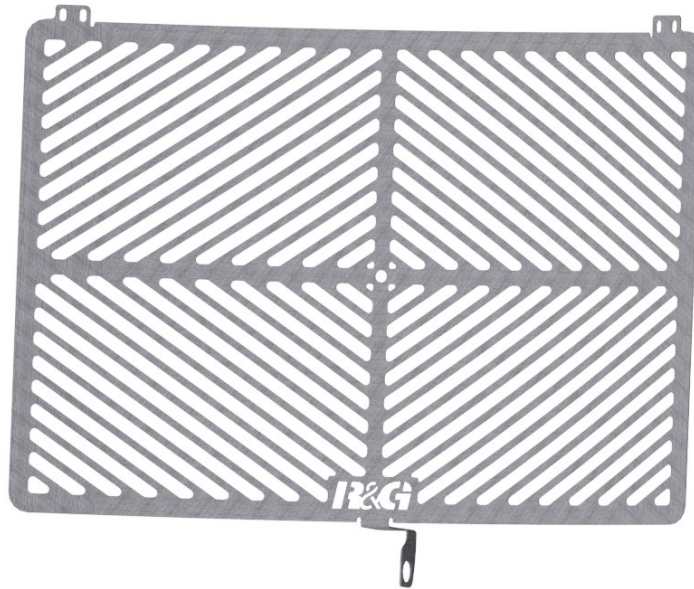

Photo A

LE KIT CONTIENT LES ARTICLES EN PHOTO ET ETIQUETTES SUR LA PAGE

LES PARTIES PRÉSENTÉES PEUVENT ÊTRE UNIQUEMENT REPRÉSENTATIVES POUR LA CLARTE DES INSTRUCTIONS

NE PAS PROCÉDER AU MONTAGE AVANT DE VOUS ÊTRE ASSURÉ QUE TOUTES LES PIÈCES SOIENT PRÉSENTES.

SVP, LIRE L'ENSEMBLE DE LA NOTICE AVANT DE PROCÉDER AU MONTAGE.
EN CAS DE DOUTE LORS DU MONTAGE, CONSULTEZ UN DE NOS REVENDEURS, OU
FAITES EFFECTUER LE MONTAGE PAR UN TECHNICIEN QUALIFIÉ.

LA FAÇON DONT LE KIT EST EMBALLÉ NE CORRESPOND PAS FORCÉMENT À LA FAÇON DE MONTER LES
PIÈCES SUR LA MOTO .

NOTEZ QUE SI LES KITS SONT EMBALLÉS AVEC DES RONDELLES EN CAOUTCHOUC SERVANT À TENIR
LES COMPOSANTS, CES RONDELLES DOIVENT ÊTRE JETÉES.

NOTICE DISPONIBLE AU TÉLÉCHARGEMENT SUR :

WWW.RG-RACING.COM

R&G Racing

Unit 1, Shelleys Lane, East Worldham, Alton, Hampshire GU34 3AQ.

Tel: +44 (0)1420 89007 Fax +44 (0)1420 87301 www.rg-racing.com Email: info@rg-racing.com



<u>OUTILS REQUIS</u>	<u>VALEURS DE SERRAGE</u>
<ul style="list-style-type: none"> • Clés Allen 4 & 5mm • Clé à molette 10mm 	M4 BOULON = 8Nm M5 BOULON = 12Nm M6 BOULON = 15Nm M8 BOULON = 20Nm M10 BOULON = 40Nm M12 BOULON = 40Nm

LEGENDE

ARTICLE No.	DESCRIPTION	QTE
ARTICLE 1	PROTECTION RADIATEUR (RAD0253)	1
ARTICLE 2	COLLIERS DE SERRAGE (CT0220)	4
ARTICLE 3	MOUSSE AUTOCOLLANTE	2

R&G Racing

Unit 1, Shelleys Lane, East Worldham, Alton, Hampshire GU34 3AQ.

Tel: +44 (0)1420 89007 Fax +44 (0)1420 87301 www.rg-racing.com Email: info@rg-racing.com



NOTICE DE MONTAGE

- Pour installer la protection radiateur sur la moto, coupez la bande de mousse fournie en morceaux de 10 mm de large et collez-les à l'arrière du cadre de la protection de radiateur, de sorte qu'ils se trouvent entre la protection radiateur et le radiateur.
- Retirez les carénages de la moto. Pour ce faire sur le côté gauche de la moto, retirez les trois fixations rapides du carénage, comme indiqué sur la flèche de la photo 1. À l'intérieur du carénage, vous devez retirer quatre rivets, comme indiqué sur les photos 2 et 3, avant que le panneau puisse doucement être tiré vers l'avant et retiré de la moto.
- Répétez ce processus pour retirer le carénage du côté droit de la moto. Veuillez noter qu'il n'y a que trois rivets à droite.
- Retirez les deux boulons qui fixent le carénage du refroidisseur d'huile, comme indiqué sur la photo 4.
- Retirez le capot en le soulevant pour dégager les deux languettes d'emplacement du refroidisseur d'huile, comme indiqué sur la photo 5.
- Retirez le boulon de fixation inférieur du radiateur, comme indiqué sur les photos 5 et 6.
- Placez la protection R&G en place et réinstallez le boulon de fixation inférieur dans la protection de radiateur, puis dans le support de radiateur, avant de serrer légèrement.
- Prenez un serre-câble et insérez-le dans l'un des trous fendus du haut, avant de l'enrouler autour du support de radiateur supérieur et de le serrer légèrement, comme indiqué sur les photos 7 et 8. Répétez cette étape de l'autre côté.
- Assurez-vous que la protection de radiateur soit correctement montée, puis serrez le boulon de fixation inférieur (en veillant à ce que le support de protection de radiateur repose sur le moyeu et contre le caoutchouc) et serrez les attaches de câble par le haut avant de couper l'excédent.
- Remontez le capot du radiateur d'huile et serrez les deux boulons.
- Remontez les carénages des deux côtés de la moto et remplacez les boulons dans le sens inverse du démontage.

ISSUE 1 01/11/2019 (BG)

R&G Racing

Unit 1, Shelleys Lane, East Worldham, Alton, Hampshire GU34 3AQ.

Tel: +44 (0)1420 89007 Fax +44 (0)1420 87301 www.rg-racing.com Email: info@rg-racing.com



MONTAGEANLEITUNG FÜR SRG0080 EDELSTAHL KÜHLERSCHUTZ YAMAHA YZF-R1M 2020-



Abbildung A

ALLE KIT-TEILE SIND UNTEN ABGEBILDET UND GEKENNZEICHNET.

DIE ABGEBILDETEN TEILE DIENEN LEDIGLICH ZUR ERKLÄRUNG.

ÜBERPRÜFEN SIE ZUERST, DASS ALLE TEILE VORHANDEN SIND.

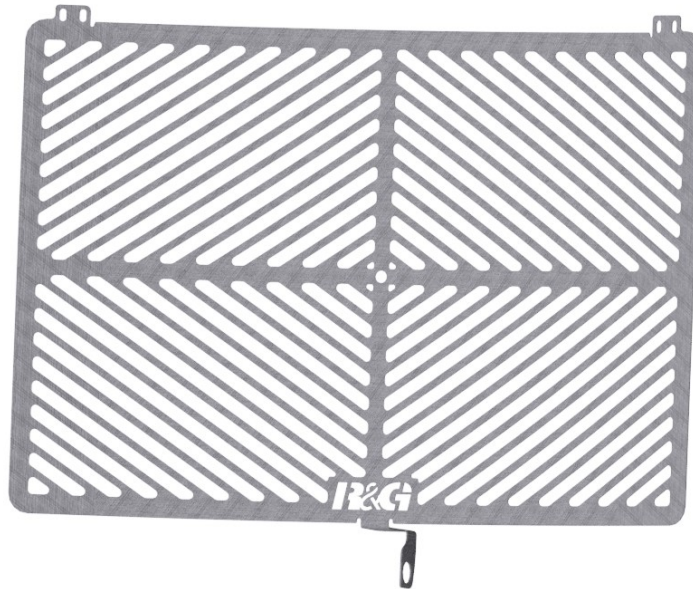
LESEN SIE DIE MONTAGEANLEITUNG KOMPLETT DURCH, BEVOR SIE ANFANGEN.

**WENN SIE BEI DER MONTAGE DIESES PRODUKTES UNSICHER SIND , BITTE EINEN
UNSERER HÄNDLER KONTAKTIEREN ODER DAS KIT VON EINEM QUALIFIZIERTEN
ZWEIRAD-MECHANIKER MONTIEREN LASSEN.**

DIE VERPACKUNG DER TEILE STELLT NICHT DIE REIHENFOLGE DER MONTAGE DAR.

HINWEIS FÜR KITS MIT PLASTIKUNTERLEGSSCHEIBEN AN DEN SCHRAUBEN –
DIESE PLASTIK-UNTERLEGSSCHEIBEN WERDEN NICHT FÜR DEN EINBAU BENÖTIGT!

**EINE DIGITALE VERSION DIESER MONTAGEANLEITUNG KANN AUF
FOLGENDER SEITE HERUNTERGELADEN WERDEN:**

WWW.RG-RACING.COM

R&G Racing

Unit 1, Shelleys Lane, East Worldham, Alton, Hampshire GU34 3AQ.

Tel: +44 (0)1420 89007 Fax +44 (0)1420 87301 www.rg-racing.com Email: info@rg-racing.com



<u>SIE BRAUCHEN FOLGENDES WERKZEUG</u>	<u>ALLGEM. ANZUGSDREHMOMENTE</u>
<ul style="list-style-type: none"> Satz Inbusschlüssel inkl. 4 und 5mm Steckschlüsselsatz inkl. 10mm 	<p>M4 SCHRAUBE = 8Nm</p> <p>M5 SCHRAUBE = 12Nm</p> <p>M6 SCHRAUBE = 15Nm</p> <p>M8 SCHRAUBE = 20Nm</p> <p>M10 SCHRAUBE = 40Nm</p> <p>M12 SCHRAUBE = 40Nm</p>

LIEFERUMFANG

ARTIKEL- NR.	BESCHREIBUNG	MENGE
ARTIKEL 1	KÜHLERSCHUTZ (RAD0253)	1
ARTIKEL 2	KABELBINDER (CT0220)	4
ARTIKEL 3	SELBSTKLEBENDER SCHAUMSTOFFSTEIFEN	2

R&G Racing

Unit 1, Shelleys Lane, East Worldham, Alton, Hampshire GU34 3AQ.

Tel: +44 (0)1420 89007 Fax +44 (0)1420 87301 www.rg-racing.com Email: info@rg-racing.com



MONTAGEANLEITUNG

- Um den Kühlerschutz am Motorrad zu montieren, schneiden Sie zuerst die mitgelieferten Schaumstoffstreifen in 10 mm breite Streifen und kleben Sie diese auf der Rückseite des Kühlerschutzrahmens, so dass sie zwischen dem Kühlerschutz und dem Kühler angebracht sind.
- Entfernen Sie die Seitenverkleidungen vom Motorrad wie folgt: Linke Seite – entfernen Sie die drei Schnellverschlüsse an der Verkleidung – siehe **Abbildung 1**. An der Innenseite der Verkleidung sind vier Plastiknieten, die entfernt werden müssen – siehe **Abbildungen 2 & 3**. Danach die Verkleidung vorsichtig nach vorne schieben und vom Motorrad entfernen.
- Wiederholen Sie diesen Vorgang an der rechten Seite des Motorrades, um die Verkleidung zu entfernen. *Hinweis: an der rechten Seite sind nur drei Plastiknieten.*
- Entfernen Sie die zwei Schrauben, die die Verkleidung für den Ölkühler befestigen—siehe **Abbildung 4**.
- Entfernen Sie die Verkleidung, indem Sie diese nach oben heben, um die Rastpunkte am Ölkühler zu lösen - siehe **Abbildung 5**.
- Entfernen Sie die untere Montageschraube vom Kühler—siehe **Abbildungen 5 & 6**.
- Den Kühlerschutz in Position bringen und die untere Montageschraube wieder montieren (durch den Kühlschutz in die Kühlerhalterung einführen und lose befestigen).
- Einen Kabelbinder durch die oberen Montageöffnungen einfädeln, dann um die obere Kühlerhalterung wickeln und lose befestigen – **siehe Abbildungen 7 & 8**. Wiederholen Sie diesen Schritt an der anderen Seite.
- Stellen Sie sicher, dass der Kühlerschutz ordnungsgemäß montiert ist (und dass die Kühlerschutzhalterung über der Nabe sitzt bzw. am Gummi anliegt) und ziehen Sie die untere Montageschraube fest, bevor Sie die Kabelbinder oben festziehen und das überschüssige Kabel abschneiden.
- Montieren Sie die Verkleidung für den Ölkühler wieder und befestigen Sie die zwei Schrauben.
- Montieren Sie die Verkleidungen an beiden Seiten des Motorrades wieder.

AUSGABE 1 01/11/2019 (BG)

R&G Racing

Unit 1, Shelleys Lane, East Worldham, Alton, Hampshire GU34 3AQ.

Tel: +44 (0)1420 89007 Fax +44 (0)1420 87301 www.rg-racing.com Email: info@rg-racing.com